



Amplifier Manual Curt 2020

3	What's in the box?
3	Frame number
4	Assembly
7	Using the Power Button
9	Ampler Bikes app
10	Maintenance
13	Electric system support
16	Charger safety manual
17	Trailer adapter
18	Specifications

What's in the box?

The bike will arrive at your doorstep in a big cardboard box. Inside this you will find:

- Your new Ampler bike
- Bike passport
- 4 mm hex key
- 6 mm hex key
- Pedals with reflectors
- Charger
- Bicycle bell
- Additional reflectors: four spoke reflectors, front and rear reflectors
- Optional: ABUS Bordo lock with holder and keys, additional charger, trailer adapter

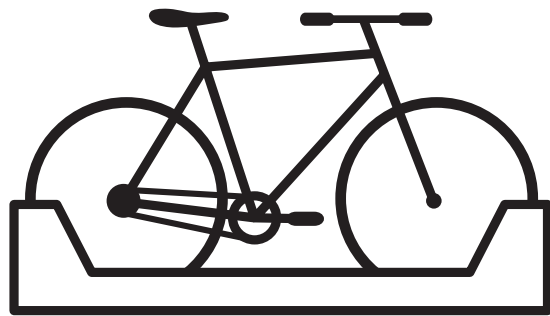

Frame number

The frame number is on the right side of the bike on the chainstay, next to the rear dropout.

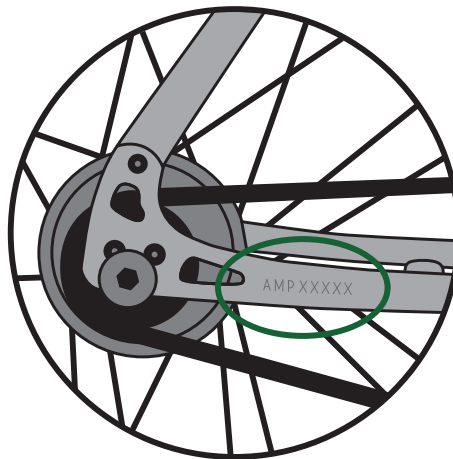

4

Assembly

You will need

- 4 mm hex key
- 6 mm hex key
- Pedals

Adjust the handlebar



1. Take the **4 mm hex key** and loosen the side bolts of the stem. Turn the handlebar to the riding position. Make sure the handlebar is aligned with the front wheel.

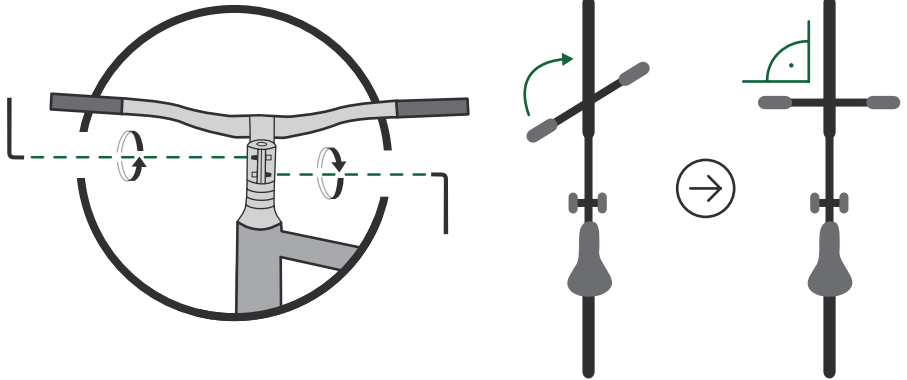

2. Take the **4 mm hex key** and lightly tighten the top cap bolt on the handlebar stem. This will make sure the headset will not have any play in it.

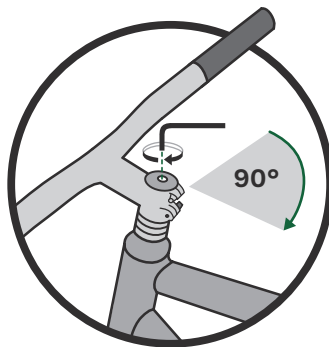

3. Take the **4 mm hex key** and carefully tighten the same stem bolts you loosened 2 steps back. Turn your handlebar left and right and make sure it spins freely. If it feels a bit too tight, loosen the stem bolts and just slightly loosen the top cap.

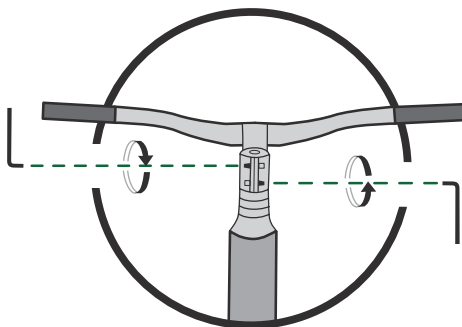

5

Assembly

Insert the pedals



1. The pedals are marked with **R** (right) or **L** (left). The R pedal goes on the chainwheel side and the L pedal goes on the non-chain-wheel side.
2. Tighten the pedals with the **6 mm hex key**.

Pedals need to be tight so make sure you put some force into it. Expect resistance only at the end of the thread, if the pedal is hard to thread in from the beginning then the threads must be inspected.

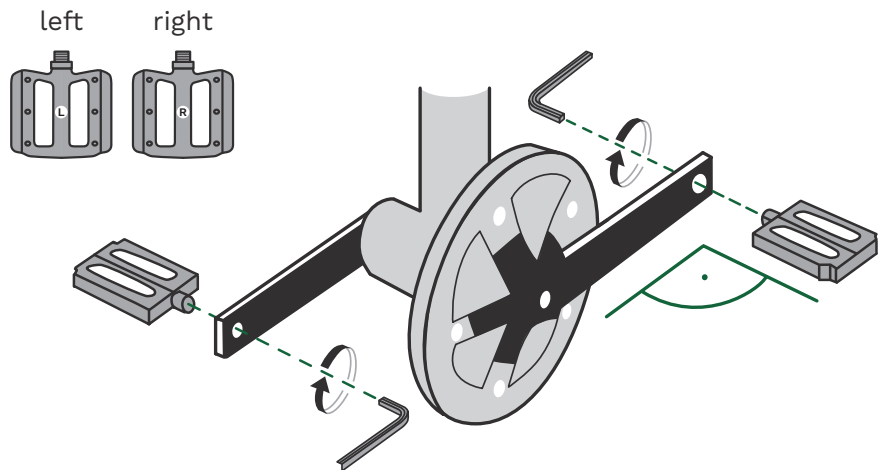

Mount the reflectors

1. Clamp the white front reflector below the front light.
2. Attach the red rear reflector to the bracket. Wrap the bracket around the seat post and secure it with the screw.
3. Attach one orange reflector on the front wheel, one on the rear wheel. Pick a spoke, place the reflector on the spoke and push the clasp at the reflector mount. Fasten it with a screwdriver.

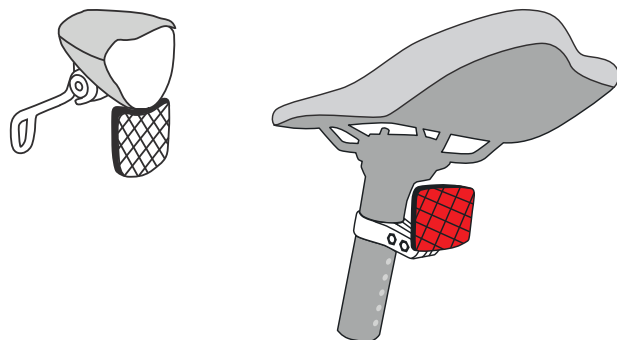

Final check before your first ride

The bike has made a long journey before reaching you, double-check the following things:

1. Check the wheels. Spin the wheels and see if they run freely.
2. Check the tyres pressure and make sure the tyres are full before your first ride. You can always check the recommended tyres pressure noted on the side walls of the tyres.
3. Test the brakes. Spin the front wheel and the rear wheel separately. Apply the brake levers separately and make sure the brakes are working correctly.
4. Check the drivetrain. Pedal by hand and check if the chain or the belt drive runs freely. Shift the gears on the 10-speed bike.
5. Check your bike visually. Does everything seem alright?

Remember to check your bike occasionally and view our Ampler Bikes Maintenance information.

Adjust the seat height



Take the **4 mm hex key** and adjust the perfect seat height

1. Place the bike in a way that allows you to support yourself against a wall when sitting on it.
2. Put one pedal in its lowest position.
3. Hop on and try to reach the pedal with your heel.
4. You have the perfect seat height when you are able to place your heel on the pedal with an almost fully stretched leg. Do not lower the seatpost below the minimum insertion length marked on the post.
5. Tighten your seat bolts.

And you are good to go!

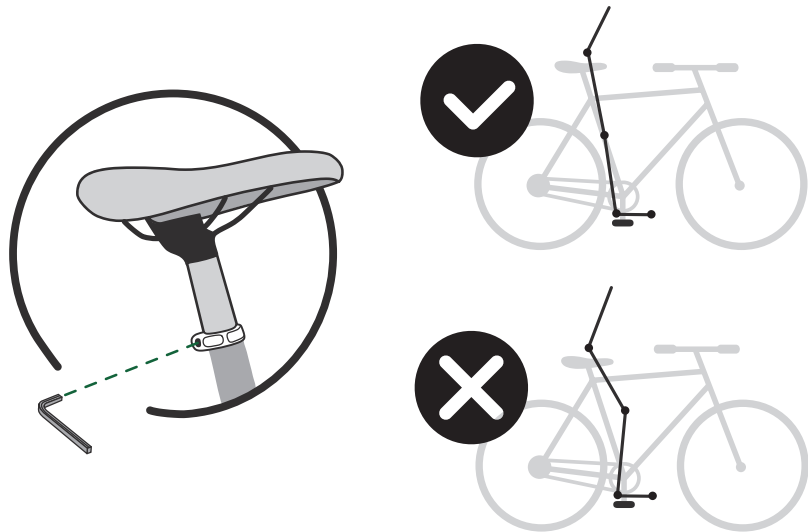

7

Using the Power Button

Turning the bike on

Just press the power button once on the power panel, located on the left side of the bike.

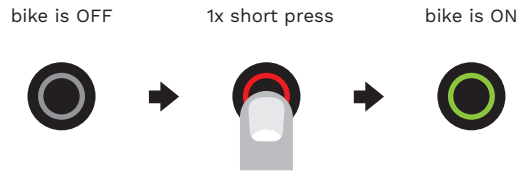

Charging the bike

The battery level is between 40%-90% when you receive it. **You can either plug in the charger and make the battery full, but you can also grab it out of the box and go.**

Charging the bike is like charging a laptop. Just connect the bike with a standard wall power outlet (110–240 V AC) and hook the magnetic charger plug to the charging socket located on the power panel and let it charge. Once the LED on the charger turns from red to green it has been fully charged. It takes about 2.5 hours from empty to full.

Ampler charger will automatically stop charging when the battery is full. There is no risk of overcharging the battery when you forget to unplug it. For your protection, please read carefully “Charger safety manual” chapter below before operating the Ampler battery charger.

State of charge

The power button also acts as a battery charge monitor. The LED colours according to the state of charge.

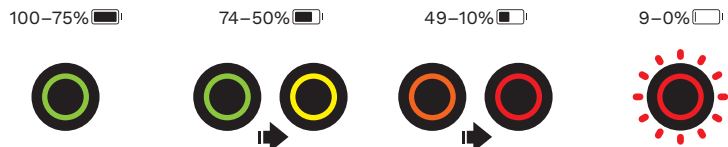

Turning the lights on

To turn the lights ON and OFF, hold the power button for 1–2 seconds. You can turn the lights on/off also from your Ampler mobile app.

The bike will remember the last setting, so the lights will be ON when you leave them on next time you power the bike.

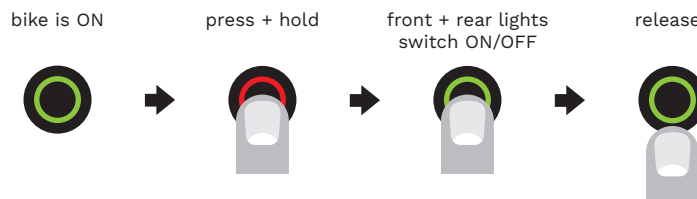

8

Using the Power Button

Changing the assist modes

The bike has two standardized assist modes:

- Normal (1) – 25 km/h, 250 W, 100%
(max assist speed, motor power, assist level)
- Boost (2) – 25 km/h, 250 W, 150%
(max assist speed, motor power, assist level)

To switch between the assist modes, hold the power button down for 3 seconds and **release it as soon as the button turns orange**. After releasing the button, it will blink ONCE if it changes to Normal Mode (assist mode 1) or TWICE if it changes to Boost Mode (assist mode 2).

You can also change the support modes on the dashboard of your Ampler app.

You can fully customise the assist modes with the Ampler Bikes app under 'Vehicle settings'.

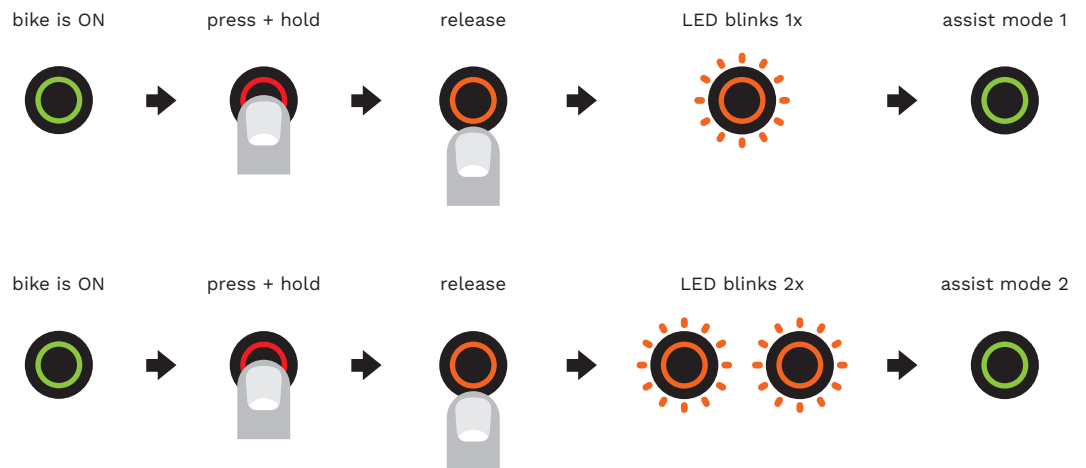

Ampler Bikes App

To fully customise your riding experience please download the Ampler Bikes app available for Android and iOS.

You can download the app for IOS from the App store, for Android (Android 4.4 onwards) in play store.

Download the app, stay close to your bike, switch on the Bluetooth, pair your smartphone with your bike and log in. The Ampler smartphone application lets you fully customise your riding experience with the Ampler e-bike. Here's some of the examples you can do:

To connect the bike with the app

1. Download the Ampler app
2. Register with your Facebook account or e-mail
3. Pair your bike with your phone over a Bluetooth connection



Adjust the motor power and max. assist speed

You have the option to change the motor parameters from the smartphone:

- motor power increase or decrease your acceleration
- max assist speed – the speed at which the electric assist stops helping you
- assist level – how much the motor assists you in proportion to your input

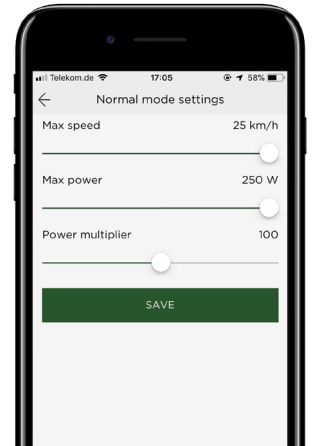

Or switch the lights on/off or to “lights only” mode.

Stay informed about your bike's electronics

- Check your battery range
- Receive updates about your bike's electronics
- Get the latest Firmware
- Contact Ampler for troubleshooting and servicing

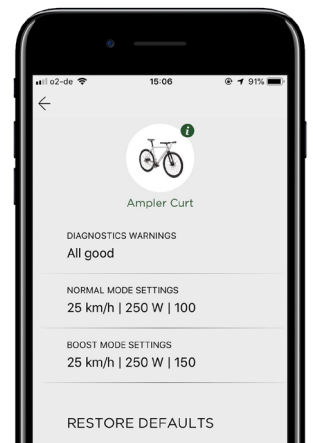

Bicycles are technical yet sensitive creatures that need a little bit of love, attention and care every now and then. Maintaining your bicycle regularly will keep it riding (and riding well) for a lot longer and will give you more range compared to a bike which has empty tyres and running brakes. It's a lot like maintaining a car – you check some things on a daily and you take it to professional service for a check-up and maintenance after a certain number of kilometres.

Take care of your bike and have the bike maintained regularly in every 3000 km or at least once a year. The actual needed maintenance interval can vary depending on your riding habits, road quality and weather conditions.

Maintaining your Ampler bike is just like maintaining a regular bicycle and all professional bike shops can carry out the maintenance of our bikes.

Clean your bike regularly

- Cleaning your bike will help to quality and keep the dirt and dust from getting into the engine and bottom bracket.
- Use soap, water and a variety of sponges and brushes to thoroughly clean the bike
- The power panel of the bike is washable and waterproof. Now and then clean (non-metallic tool) and lubricate the charging port with a multi-purpose oil (for example multi-spray).
- Avoid using pressure washers, as the pressure driven water will get dirt, sand and dust particles inside tiny compartments, causing rust and problems later down the line.

Check the tyres

- Check tyre pressure regularly – the recommended tyre pressure is given on the side wall of the tyre.
- The tyres should always be inflated so that the pressure is within the manufacturer's recommendation for minimum and maximum tyre pressure. Full will keep the battery range high and protect the rim and tyre against damages.
- **By the way:** If you are more of a lightweight, you can use the lower limit of the recommended tyre pressure. If you weigh a little more or regularly load heavy items onto the carrier of your rear carrier, stay just a little below the maximum pressure. How can you even know the current air pressure? The best way to find out is to buy a stand pump with a pressure gauge or to stop by someone who has one.
- Look out for tyre wear. Depending on how and where you ride your bike, the tyres can wear at a different pace. If you notice the tread worn out, change the tyres.
- If it gets cold and icy outside, get some winter tyres. Before you buy any, make sure that they fit the rims and frame of your Ampler e-bike. You can either get advice on this at a bike shop, where the bicycle tyres will certainly be fitted for a small extra charge; or you can contact our support team, who can advise you on technical questions
(phone: +049 30 5683 7159 / e-mail: hello@amplerbikes.com).

Check the chain

- Check the chain tension – if it has slackened over time (it looks saggy), get it adjusted. If you feel you are not right for the job, you can easily get it done in your local bicycle shop.
- Replace the chain before the wear is reached to 0,75%
- Making sure your chain is lubed will prevent unexpected and premature wear to the drivetrain.
- If the chain feels a little dry, clean it with a rag and then add some chain lubricant. Spin the pedals around a couple of times to spread the lubricant evenly.
- A carbon belt drive does not need any oil, however needs to be cleaned after riding in dirty conditions with water. You can apply a thin coating of dry silicone spray to the tooth side of the belt if necessary.
- Avoid using the lubricant on brake pads, rotors or rims. Spray is not recommended, use liquid oil.

Check the brakes

- Check the brakes regularly – they should be cleaned and adjusted.
- Over time the disc brakes get less efficient at breaking. To stay safe, get your brakes inspected, serviced and changed if necessary by a professional workshop.
- Squeezing your brakes down should feel solid and consistent – the lever should not touch the handlebar. If you feel that your brakes aren't effective, get a professional to check them out.
- Take a good look at the brake pads on your bike every few weeks to see how they are holding up. There shouldn't be any dirt or oil on the pads. Often times, the brakes will make a howling noise if there's oil on them.
- Check the brake hoses for wear and tear – if you can see that the hose is crumbling or broken in any place, get it checked immediately by a professional.

Keep the bolts tight

- After first couple of weeks check the bolts and nuts. If there is too much play in the bolts, tighten them up a little bit and see if you can identify the cause of the looseness. Don't tighten the bolts too far.
- Re-tighten the bolts on the handlebar if needed.
- Check the crank bolts (8 mm hex key, not included), tighten them if needed.
Re-tighten the pedals, using the key that came with the bike.
- Re-tighten the bottom bracket eccentric bolts.

Motor and battery maintenance

- If you're not riding and charging your bike consistently, charge it every five–six week or so to maintain the state of the battery. Due to Bluetooth the bike has a little power consumption even when switched off.
- Do not keep the bike in blazing sun or freezing cold over the extended period if it is not being used.
- Make sure the charging socket and the magnetic plug are dry and clean before you plug in the charger.
- **Store the bike in a dry place over the winter** – it doesn't need to be heated, however below 0 is not recommended.
- Charging the battery should take place indoors (above 0 degrees) or/ and in dry environment. Do not keep the charger outside.

Beware that when you bike in the cold, the range and battery capacity will be lower than average. This is completely normal, and it won't affect the battery's overall state or lifespan.

- When you finish cycling in the cold, make sure that the bike has time to warm up a little before you charge it.

Professional maintenance schedule

Maintaining your Ampler bike is just like maintaining a regular bicycle and all professional bike shops can carry out the maintenance of our bikes.

The first professional check-up should take place after the first 500 kilometres – this will ensure that everything is working as it should. After that, have the bike service regularly every 3000 km.

If you ride often and don't count the riding distance, make sure to take it to a professional bike shop for maintenance at least twice every season, ideally even three times

- Before the start of the season
- Mid-way through
- At the end of the season.

This way, all the important aspects like brake oil levels, and the condition of brake pads and tyres get checked, and the internal parts like the crank set and wheel hubs get cleaned thoroughly.

That's it – while it's a long list of things to look out for, it's good to remember that maintaining your bike often is important for both safety and ride experience reasons.

Have fun riding!

Electric system support

Amplifier hardware (the battery, controller and sensors) are inserted into the down tube. This keeps the bike clean, the weight down, and the components safe from outside elements such as the rain and cold temperature.

The hardware doesn't need any special maintenance. However, we recommend to keep your bike Firmware up to date and calibrate your bike sensors from time to time. This will help to keep your bike in a good shape for longer time.

Software restart

Software restart clears up your bike's memory and starts it fresh. It helps to resolve any problems connected to the hardware, and any communication problems between the bike and the mobile app.

To reset your bike

1. Hold down the power button for 10 seconds. This will reset and turn off your bike.
2. Turn on the bike again from the power button.

Torque sensor calibration

Amplifier bikes are pedelecs and they have sensors regulating the motor, measuring the speed of pedalling and your own input power. Therefore, the bike is easy to use and the motor power is controlled according to your own pedaling force. This creates a safe and smooth riding experience.

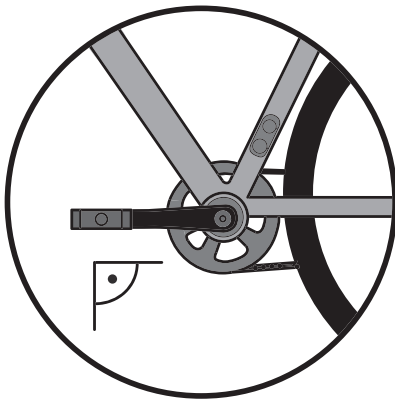

We recommend to calibrate your bike's torque sensor **every 3–6 months**, or in case the bike feels over- or underpowered. Torque sensor calibration is done via the Amplifier app:

1. Adjust the left crank forward, parallel to the ground.
2. Connect the Amplifier app with your bike via Bluetooth
3. Open **'Vehicle'** setting from the menu
4. Click on **'torque sensor calibration'**
5. The LED blinks in **orange**
6. The LED will turn **green** once the calibration is successful

Re-adjusting the sensor signal helps to improve your bike's responsiveness and power to its original figures.

Every Amplifier has a motor controller – the so-called brain of your bike that connects all the electronics and makes sure everything runs smoothly. The motor controller is managed by Firmware (the software that controls the hardware). To guarantee the best riding experience, we recommend keeping your bike's Firmware up to date.

Factory calibration

Factory calibration will adjust all your bike's sensors and align the functionality of all electronic components. Use this calibration only if any of the electronic components have been replaced or only if recommended by Amplifier support.



CAUTION! During the factory calibration, the motor starts on its own and thus the rear wheel will start spinning. It is necessary for you to

lift the rear wheel off the ground during the whole process to prevent damages or injury.

For a successful factory calibration:

1. Lift the bike so that the rear wheel can spin freely.
2. Place the left crank horizontally towards the ground facing towards the direction of travel.
3. Hold down the button (approx. 7-10 seconds) until it turns GREEN from RED. As soon as the LED turns GREEN, release the button.
4. The LED starts blinking ORANGE and the bike is processing the calibration of torque and motor sensors. After some moments, the motor starts and thus the wheel starts spinning for around 15 seconds. After the motor stops, the LED should blink GREEN after about 5 seconds and the bike will automatically turn off. You can put the wheel down again.

Now the motor and torque sensor are calibrated and assist modes are set to default, you might need to adjust them again through the app. Turn the bike on again and you are ready to use your Ampler!

Firmware update

Firmware update is done via the Ampler mobile app. If your bike is connected to the app, you will get a notification in your app about the new available Firmware. Please go to the **Vehicle settings** to update your Firmware.

Before starting the update, make sure:

- You have **the latest Ampler app version**
- You have internet connection on your phone
- Your phone's battery is not running low
- The battery level of the bike is more than 25%
- You have registered and paired the app with your bike

The update is done over Bluetooth in several steps. All the steps are almost identical, and they need to be done in a row. This means that after completing the first update, if there will be a second update still available – you will also need to complete this. The updates should take about a minute to complete.

Troubleshooting the Firmware update

If you experience any problems with updating the Firmware, please follow troubleshooting instructions below.

Flow A

1. Turn Bluetooth OFF
2. Turn Bluetooth ON
3. Wait 10 seconds for connecting

If there is no connection, start flow B. If the connection is established, check if there is another Firmware update available and complete that one as well.

Flow B

1. Close the Ampler app on the background

2. Go to Bluetooth settings
3. Find the Ampler Bike Bluetooth ID under your Bluetooth devices and click the “Info” button. Press “Forgot This Device”
4. Turn Bluetooth OFF and then back ON under settings
5. Open the Ampler app
6. Pair your bike with your smartphone
7. Check if the update is available and complete the update

If a new firmware version becomes available in the future, you will be notified within the app. Meanwhile you can check the firmware status in the Vehicle view – if the firmware is up to date, you’ll see the information in the lower part of the screen in the vehicle view.

For your protection, please read this manual carefully before operating the Ampler battery charger.

Important



The charger is designed for indoor use only. Do not expose it to rain, snow or expose the device to elevated temperatures.

Only use the genuine Ampler charger designated for your Ampler e-bike. Do not use this charger for other batteries. Also, do not use other battery chargers for your Ampler e-bike.

Store the charger in a cool and dry place.

Always check that the magnetic charging plug and connector are clean and dry. Any electrically conducting particles at the connection can damage the charger or the electrical system of the e-bike.

During charging the charger can become moderately hot. Always place the charger in a well-ventilated place and keep it away from combustible materials.

Children should be supervised by an adult when using the product.

This charger must not be disposed with domestic waste and should be disposed at an authorized place for recycling electrical appliances.

Trailer adapter

Ampler trailer adapter is compatible with most Thule, Burley and Croozer trailers.

1. Remove the nut from the left side of the rear dropout, located next to the motor. Do not remove the motor torque washer from the dropout – keep it attached to the axle.
2. Attach the Ampler motor axle adapter to the frame. Use a 19 mm wrench and make sure the axle adapter is securely fastened.
3. Finally, insert the two security washers, Thule trailer mount and fasten them by using a 13 mm wrench to tighten the outside bolt.

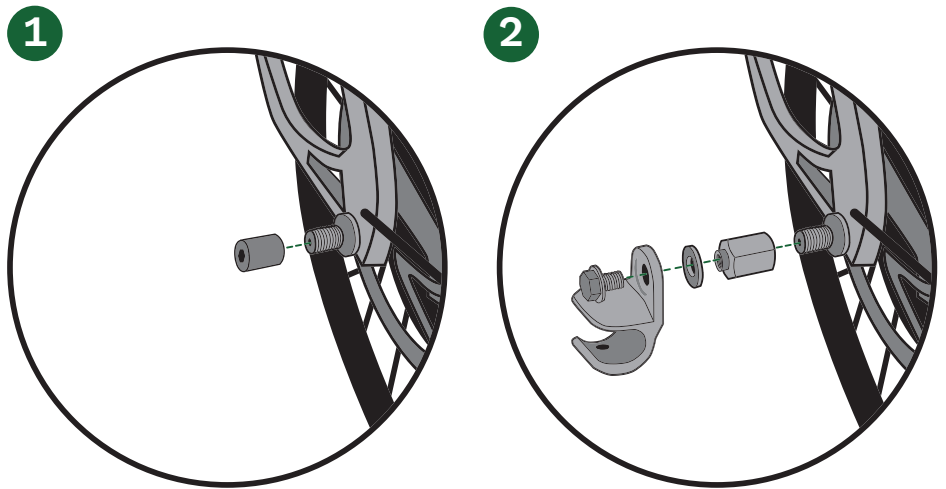

Sizes	Small 50 cm, Medium 54 cm, Large 58 cm
Parts	
Frame	Aluminum Alloy 6061, Double butted
Fork	Carbon 1 1/8"- 1 1/2", 12 mm Thru-axle
Crankset	Alloy 170 mm
Gear shift	<p>Single-speed configuration: 60/20 Gates Carbon Drive CDX Front sprocket: CDX 60 tooth Rear sprocket: CDX 20 tooth</p> <p>10-gear configuration: Shimano Deore M6000 10-speed upgrade Derailleur: Shimano M6000 Shifter: Shimano M6000 10-spd Cassette: CS-5700 11-28T Chain: Shimano/Sram compatible 10-speed chain Chainring: 42 T Narrow/Wide</p>
Brakes	Shimano M6000 hydraulic disc brakes
Brake pads	Shimano G02S
Rims	Asymmetrical 28 mm rims with sealed bearing hubs, 36H
Tyres	Continental Grand Prix 4-Season, 32-622 mm
Wheels	28"
Weight	13.5 kg (Single-speed belt) / 14.3 kg (10-speed chain)
Electronics	
Assist speed	25 km/h
Range	45–100 km depending on terrain and assist mode
Battery	48 V 336 Wh LG Li-ion battery
Motor	48 V 250 W rear hub motor
Control mode	Precise pedal torque-sensing motor control system
Connectivity	Smartphone connectivity with option to change motor settings
Charger	3A Li-ion charger with Rosenberger magnetic plug
Charging time	2.5 hours for a full charge
Lights	<p>Front: Busch+Müller IQ2 Eyc Rear: LightSKIN integrated seat post LED light (StVZO approved)</p>